

DISPLAY | Multidecks

DISPLAY ► WALL SITE MULTIDECK

VS 15

CUSTOMIZATION AVAILABLE
PERSONALIZZAZIONE DISPONIBILE

MADE IN ITALY

30 mm | M1 | -1°C / +5°C | **E** ENERGY CLASS | 3 | +25°C/60RH | LED | GAS R452A

DETAILS



Hanging meat bar and hooks



Nightblind (Fabric - Grey color)



The items can be supplied either with lockable castor



GENERAL FEATURES

- Wall showcase with hanging meat bar (Width: 1510mm)
- External chestnut laminate and black coated steel internally
- Ventilated Cooling
- Foaming Agent Cyclopentane (30mm per side - CFC Free)
- Automatic compressor cycle defrost
- Digital display control
- Interior LED light (with independent switch)
- Independent main switch
- Adjustable shelves: 1 Pcs + hanging meat bar and 6 hooks
- Panoramic ends providing the maximum visibility of the goods
- Nightblind for an optimal energy conservation during nights (Fabric - Grey color)
- Charcoal black bumper
- N.4 Adjustable feet
- Energy efficiency class: E

TECHNICAL SPECIFICATIONS

Capacity	761 L
Temperature	M1 (-1°C-+5°C)
Consumption	20.1 kWh/24h
Rated Power	1909 W
Noise level	70 dB(A)
Net Weight	244 Kg
Gross Weight	290 Kg
External Dimensions (WxDxH mm)	1510x635x2095
Internal Dimensions (WxDxH mm)	1446x335x1165
Packaging dimensions (WxDxH mm)	1620x760x2265
Loading quantities 20'/40'/40'HQ	7/14/14

PRODUCT DIMENSIONS

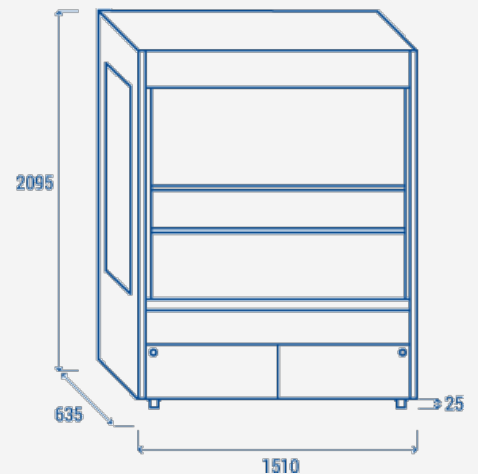

CERTIFICATION

CE RoHS

